

# Cooperative Layered Video Multicast using Randomized Distributed Space Time Codes

Özgü Alay, Pei Liu, Yao Wang, Elza Erkip and Shivendra Panwar

Department of Electrical and Computer Engineering, Polytechnic Institute of NYU, Brooklyn, NY

E-mails: ozgu@vision.poly.edu, {pliu,yao,elza}@poly.edu, panwar@catt.poly.edu

**Abstract**—With the increased popularity of mobile multimedia services, efficient and robust video multicast strategies are of critical importance. Cooperative communications has been shown to improve the robustness and the data rates for point-to-point transmission. In this paper, a two-hop cooperative transmission scheme for multicast in infrastructure-based networks is used, where multiple relays forward the data simultaneously using Randomized Distributed Space Time Codes (RDSTC). This randomized cooperative transmission is further integrated with layered video coding and packet level Forward Error Correction (FEC) to enable efficient and robust video multicast. Three different schemes are proposed to find the system operating parameters based on the availability of the channel information at the source station: RDSTC with full channel information, RDSTC with limited channel information and RDSTC with node count. The performance of these three schemes are compared with rate adaptive direct transmission and conventional multicast that does not use rate adaptation. The results show that while rate-adaptive direct transmission provides better video quality than conventional multicast, all three proposed randomized cooperative schemes outperform both strategies significantly as long as the network has enough nodes. Furthermore, the performance gap between RDSTC with full channel information and RDSTC with limited channel information or node count is relatively small, indicating the robustness of the proposed cooperative multicast system using RDSTC.

**Index Terms:** layered video coding, user cooperation, randomized distributed space time coding, wireless networks, video multicast

## I. INTRODUCTION

In recent years, the progress in multimedia technology has given rise to the demand for video applications over wireless networks. Multicasting is a bandwidth efficient method to deliver popular events to many wireless nodes, since it saves network resources by spreading the same data stream across multiple receivers. However, the high packet loss ratio and bandwidth variations of wireless channels make video multicast over wireless networks a challenging problem.

In this paper, we consider multicasting in an infrastructure-based network (i.e. Wireless Local Area Networks (WLAN) or cellular networks). We study maximizing the video quality

This work is supported in part by National Science Foundation (NSF) under the awards 0430885 and 0905446, and the New York State Center for Advanced Technology in Telecommunications (CATT). The work is also supported by Wireless Internet Center for Advanced Technology (WICAT), an NSF Industry/University Cooperative Research Center at Polytechnic Institute of NYU. Presented in part at INFOCOM-MOVID 2009 and ICASSP 2010.

Copyright (c) 2010 IEEE. Personal use of this material is permitted. However, permission to use this material for any other purposes must be obtained from the IEEE by sending an email to pubs-permissions@ieee.org.

for the multicast nodes in the coverage range of an Access Point (AP) or Base Station (BS) considering both the wireless network and multimedia characteristics. To achieve this goal, we propose to utilize user cooperation techniques to combat path loss and fading as well as to boost the transmission rates. Specifically, we employ Randomized Distributed Space Time Codes (RDSTC) where the nodes that receive the video packets can act as relays and transmit simultaneously. We further employ packet level FEC to handle packet losses in the network. We choose the amount of packet level FEC applied such that there is no observable quality degradation in the video. Finally, we employ layered video coding and configure the system parameters to provide different video quality levels commensurate with nodes' channel conditions.

User cooperation where terminals process and forward the overheard signal transmitted by other nodes to their intended destination is an effective technique to combat path loss and fading [1], [2]. Cooperation techniques can be used to provide spatial diversity [3] as well as reduction in source distortion (including video) in point-to-point communications (unicast) by providing unequal error protection [4], [5]. The majority of the research on cooperation (including the above mentioned studies) considers a unicast scenario. However, cooperative transmission is especially suitable for multicast not only because of its ability to substantially reduce the packet losses, but also because the relays are part of the multicast group, and hence are free from the incentive and security concerns that may impact the deployment of cooperation for point-to-point communications.

In general, there may be more than one node that can overhear the packets sent by the source station. If we let these nodes transmit cooperatively to the destination, significant diversity gains can be accomplished. Without physical layer cooperation (i.e. utilizing cooperation in MAC and upper layers), these nodes can only relay sequentially, but this results in a loss of spectral efficiency. A more efficient way is for the nodes to relay simultaneously utilizing cooperation at physical layer, e.g. using a distributed space-time code (DSTC) [3]. The basic idea behind DSTC is to coordinate and synchronize the relays such that each relay acts as one antenna of a regular Space Time Code (STC) [6],[7]. However, in order to realize such a system, each relay participating in a DSTC needs to know exactly which antenna it will mimic in the underlying STC. Furthermore, based on the dimension of the underlying STC used, a fixed number of relays is chosen. Even though there may be other nodes who decode the source information

correctly, they are not allowed to transmit, thus forfeiting the potential diversity and coding gains. Finally, a DSTC requires tight synchronization of the relay nodes, putting a heavy burden on the MAC and physical layers.

In order to circumvent these problems, RDSTC [8] can be used where each relay transmits a random linear combination of antenna waveforms. RDSTC not only eliminates the antenna index assignment, but also allows variable number of relays that are selected on the fly. Furthermore, RDSTC does not need as tight synchronization among relays as that required by DSTC [10]. Randomized coding for unicast transmission in a wireless network is described in [11], where the impact on the MAC layer performance is also discussed. A joint physical and MAC design for unicast transmission using a randomized cooperative scheme is described in [12], [13]. RDSTC is especially attractive for multicast since the nodes that receive the packets can act as relays and transmit simultaneously, without the need for relay selection and scheduling. Hence our proposed framework is based on RDSTC.

In order to handle packet losses at each hop of the cooperative system, we further employ packet level FEC. Note that in a multicast system, since each node experiences different packet loss patterns than its neighbors, a simple ARQ (Automatic Repeat reQuest) based scheme results in a large number of retransmissions. The advantage of using packet level FEC for multicasting is that any parity packet can be used to correct independent packet losses among different receivers.

The main contribution of this paper is the integration of layered video coding, RDSTC based user cooperation and packet level FEC to enable efficient and robust video multicast. Our emphasis is on selection of system operating parameters that maximize the sustainable video rate for a given channel environment, at which all users or a larger percentage of users can receive the video with negligible packet loss effect. The operating parameters considered include transmission rates of the first and second hops, the STC dimension of the RDSTC code as well as the FEC rate. Note that because we choose the FEC rate so that packet loss effect is negligible, maximizing the video rate is equivalent to maximizing the video quality. We use video quality to evaluate the performance of the system, however, the approach can be extended to include the power consumption and coverage range as a performance metric. We propose three different schemes which differ in the assumed available channel information. The first one (RDSTC with full channel information) was partially studied in [14], [15] and assumes that the source station knows the average received SNRs between itself and each receiver node as well as between all pairs of nodes. This can be achieved by exchanging control signals among the nodes to measure the average SNR, and then this information is transmitted back to the source station. Note that the overhead due to control signals may be formidable, therefore the next two schemes we study are heuristic and requires less control signalling. The second scheme (RDSTC with limited channel information), assumes that the source station only knows the channel information between the nodes and itself. Finally, the third scheme (RDSTC with node count) considers that the source station only knows the number of nodes in its coverage range. For each

of these schemes, we find the system operating parameters (transmission rates of both hops, the STC dimension and the FEC rate) based on the channel information, and evaluate the achievable video rate. We compare the results of the above three schemes with rate adaptive direct transmission [18] and conventional multicast. We further consider performance of a layered cooperative multicast system, which provides better video quality to the nodes with better channel conditions.

Wireless video multicast has been studied both in infrastructure based networks and self-organizing (ad-hoc) networks. In infrastructure-based wireless networks, [16]-[17] studied error control in wireless video multicast. A rate-adaptive multicast where rate adaptation is integrated with packet level FEC is considered in [18] where the authors showed that joint rate and FEC adaptation significantly improves the quality in a multicast system. Scalable (layered) video coding is utilized in [19]-[22] to address the heterogeneity of multicast nodes. In [23],[24], multicast routing protocols are discussed for ad-hoc networks. The authors of [25],[26] also considered video multicast over ad-hoc networks, where the use of multiple description video is proposed to overcome the unreliability of wireless links. Studies on multicast in mesh networks in general consider building an efficient multicast tree. Chou et al. [27] considered video multicast for multi-rate wireless mesh networks where the construction of the multicast tree along with scheduling for low latency multicast were explored. Layered video multicast is studied in mesh networks [28]. Although the mentioned studies consider layered video multicast in a multi-hop network, none of those papers have considered the use of user cooperation combined with layered video and application layer FEC in order to provide robust video multicast. Recently, we studied a multi-hop layered multicast system (with no physical layer combining), where multiple relays transmit sequentially in time, and showed the benefits of such a scheme both numerically and experimentally [29]. However, with such an approach, the throughput of the system is limited due to the sequential transmission.

This paper is organized as follows. We introduce the system model in Section II. Section III formulates the computation of bit error rates for both direct transmission and RDSTC. We discuss the packet level FEC along with the resulting video rate for direct transmission in Section IV. We formulate the video rate for randomized cooperation for both single layer and layered transmission in Section V. In Section VI, we discuss the selection of system operating parameters under full channel information as well as partial channel information. Section VII discusses the simulation setup and reports the results for different schemes. We conclude the paper in Section VIII.

## II. SYSTEM MODEL

We study an infrastructure-based wireless network (such as Wireless LAN or cellular), and assume a source station (a BS or AP) is multicasting a compressed video stream to nodes within its coverage range of radius,  $r_d$ . We assume the nodes are randomly uniformly distributed and we define the *node placement* as one realization of the node locations. All nodes in the network are equipped with one antenna and can transmit

$R_d$	Direct transmission rate for single layer (bits/sec)
$R_{d,b}, R_{d,e}$	Direct transmission rates for base and enhancement layers (bits/sec)
$R_1, R_2$	First and second hop transmission rates for single layer RDSTC (bits/sec)
$R_{1,b}, R_{2,b}$	First and second hop transmission rates for the base layer (bits/sec)
$R_{1,e}, R_{2,e}$	First and second hop transmission rates for the enhancement layer (bits/sec)
$\gamma_d, \gamma_c$	FEC rates for single layer direct transmission and RDSTC
$\gamma_{d,b}, \gamma_{d,e}$	Base and enhancement layer FEC rates with direct transmission
$\gamma_b, \gamma_e$	Base and enhancement layer FEC rates with RDSTC
$t_b, t_e$	Base and enhancement layer transmission time fractions (for both direct and RDSTC)
$R_{v_d}, R_{v_c}$	Received video rates for single layer direct transmission and RDSTC (bits/sec)
$R_{v_b}, R_{v_e}$	Received video rates for base and enhancement layers (for both direct and RDSTC)(bits/sec)
$L, L_b, L_e$	Space time code dimension (for single layer, base and enhancement layers)
$\eta$	STC code rate
$N_T$	Total number of nodes
$\epsilon_{max}$	Maximum packet error rate among all nodes
$N$	Number of relays

TABLE I  
NOTATION

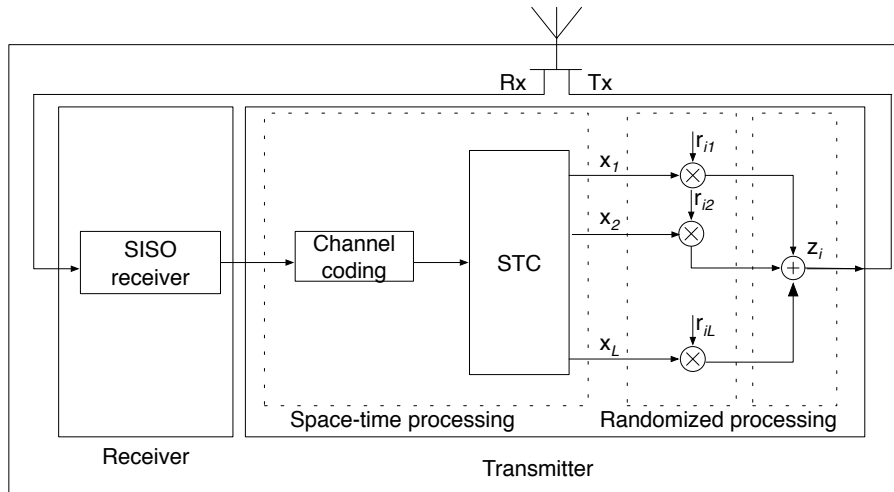

Fig. 1. Transmitter and receiver architecture at the relay nodes

at different transmission rates supported by the underlying physical layer. Note that each physical layer transmission rate,  $R$ , corresponds to a modulation level, and channel code rate. In accordance with IEEE 802.11g [30], we consider only square constellations. We assume that the channel between the source station and each node, and that between each pair of nodes, experience independent slow Rayleigh fading. Note that when the minimum spacing between two antennas is sufficiently greater than half wavelength, the correlation of the transmitted signals by the antennas is low enough that the associated fading can be considered independent. We assume that the fading is constant over the transmission time of a single packet, but changes independently from packet to packet. This is reasonable for video communication and will be justified in Section VII. We also assume each channel experiences path loss such that the received power decays exponentially in distance for a given path loss exponent.

Table I summarizes the notation used in this paper. For the baseline direct transmission system, the source station transmits the packets at a physical layer transmission rate of  $R_d$  bits/sec. In order to correct the remaining packet errors after physical layer channel coding, we employ packet level FEC across video packets. In our design, we apply a packet

level FEC rate of  $\gamma_d$  such that all the nodes in the coverage area receive the video with a FEC decoding failure probability below a certain threshold. We will further discuss the packet level FEC in Section IV.

The proposed cooperative system employs RDSTC [8] as illustrated in Figure 1, wherein a single-antenna relay employs a regular single-input and single output (SISO) decoder to decode the information sent by the source station in the first hop. Each potential relay detects bit errors in each received packet using cyclic redundancy check (CRC) and forwards the packet only when the packet is correctly received. To forward, the relay re-encodes the information and then passes the coded bits through a STC encoder. The output from the STC encoder is in the form of  $L$  parallel streams with each stream corresponding to an antenna in a system with  $L$  transmit antennas. However, in contrast to a multi-antenna transmitter, in a RDSTC system, the relay transmits a random linear weighted combination of all  $L$  streams, where the weights are denoted by  $\mathbf{r}_n = [r_{n1} \ r_{n2} \ \dots \ r_{nL}]$ , with  $n$  denoting the index of the node,  $n = 1, 2, \dots, N$ . The effect of different randomization vectors  $\mathbf{r}_i$  is discussed in [8]. The diversity of RDSTC based cooperation is the minimum of the STC dimension  $L$  and the number of relays. At the receiver, the

equivalent channel gain (which includes the channel gain and the randomization matrix) is estimated using pilot signals [8]. Therefore, decoders already designed for space-time code reception can be directly used for RDSTC decoding.

For multicast with RDSTC, the source station transmits a packet at a physical layer transmission rate of  $R_1$  bits/sec. The nodes that receive the packet correctly form the relay set, and are called the Hop-1 nodes, as depicted in Figure 2 where a snapshot of the network for some fixed fading state is illustrated. All nodes that can correctly receive a packet from the source station re-encode and transmit the packet simultaneously at a physical layer transmission rate of  $R_2$  bits/sec using RDSTC with dimension  $L$ . The nodes which fail to receive the source station transmission correctly are called Hop-2 nodes. Hop-2 nodes listen to relay transmissions to decode the original source packet. We assume that the source station does not transmit with the relays in the second hop, and Hop-2 nodes do not use the noisy signal received from the source station in Hop-1 in decoding. Combining source station and relay signals would increase the performance at Hop-2 nodes at the expense of a more complex receiver. Note that as we increase  $R_1$ , the number of Hop-1 nodes reduces. Therefore, the sustainable data rate for the second hop,  $R_2$ , is expected to be lower in order to cover all the nodes. On the other hand, if the first hop rate,  $R_1$  is lower, more nodes participate in the second hop transmission, and hence the second hop transmission rate,  $R_2$  can be higher. In order to handle packet losses, the source station employs packet level FEC at a rate  $\gamma_c$ . Here, we assume the Hop-1 nodes do not differentiate between the source and FEC (parity) packets. The source station chooses  $\gamma_c$  such that after two hop transmission, the FEC decoding failure probability at each node is below a threshold. Note that due to fading, successful reception of a packet does not necessarily depend on the distance to the source station. Therefore, some of the nodes that are closer to the source station may experience a bad fading level and may not be able to receive the packet. On the other hand, there are some nodes that observe a good fading level and receive the packet even though they are far away from the source station. Also, due to different fading levels for each packet, whether a node belongs to Hop-1 or Hop-2 can change from packet to packet.

Scalable video compression such as MGS quality scalability mode of H.264/SVC [33], allows for coding a video into multiple layers so that reception of more layers leads to better quality. In multicast, layered coding allows differentiated quality for different nodes based on their average channel conditions. Furthermore, layered coding can be combined with cooperation and FEC for unequal error protection. In addition to the aforementioned non-layered system, we also examined a layered system where the source station and relays transmit packets from different layers in separate time slots. For direct transmission, we assume the source station transmits the base layer packets at a rate  $R_{d,b}$  bits/sec with a FEC rate of  $\gamma_{d,b}$  and the enhancement layer packets at a rate  $R_{d,e}$  bits/sec with a FEC rate of  $\gamma_{d,e}$ . For cooperative multicast, the source station transmits the base layer packets at a rate  $R_{1,b}$  bits/sec and the relays transmit the base layer packets at a rate  $R_{2,b}$  bits/sec

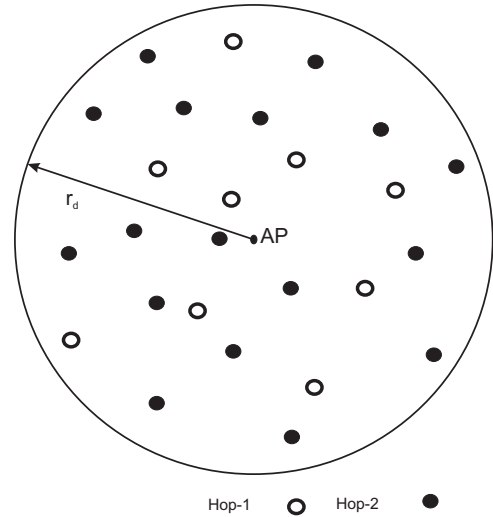

Fig. 2. Snapshot of the network.

and STC dimension  $L_b$ , both with a FEC rate of  $\gamma_b$ . Similarly, the transmission rates for enhancement layer packets for the first and second hop are  $R_{1,e}$  and  $R_{2,e}$ , respectively, with a STC dimension of  $L_e$  and FEC rate of  $\gamma_e$ . We denote the percentage of nodes that receive both base and enhancement layers by  $\mu$ , consequently the percentage of nodes that receive only the base layer is  $(100 - \mu)$ . We configure the transmission rates and FEC rates to maximize the enhancement layer rate, while fixing the base layer rate at a preset constant (equal or higher than the video rate supportable by single layer direct transmission), for a given  $\mu$ .

### III. COMPUTATION OF BIT AND PACKET ERROR RATES

In the following subsections, we first discuss the computation of the instantaneous Bit Error Rate (BER) (for each channel realization), both for direct transmission and RDSTC. Then, using this BER and the underlying channel code, we will describe the computation of average Packet Error Rate (PER). The PER in return will be used to determine the required packet level FEC rate.

#### A. BER of Single Link

We assume that at time  $k$  the source station transmits a symbol  $\mathbf{x}(k)$  with energy  $E_{s,s}$  and  $m^{th}$  node experiences an instantaneous channel gain of  $h_m$  from the source station. Then the received signal at the  $m^{th}$  node at time  $k$  can be written as:

$$y_m(k) = \sqrt{E_{s,s}} h_m x(k) + w_m(k) \quad (1)$$

where  $w_m$  is additive complex white Gaussian noise with variance  $N_0$ , and  $h_m$  is the Rayleigh random variable representing the channel gain. We can express the instantaneous received SNR at the  $m^{th}$  node,  $\zeta_m$ , as

$$\zeta_m(\bar{\zeta}, h_m) = \frac{E_{s,s} \|h_m\|^2}{N_0} = \bar{\zeta} \|h_m\|^2 \quad (2)$$

where  $\bar{\zeta}$  is the average transmit SNR.

For a M-QAM square constellation, the symbol error rate can be computed as [34]:

$$P_s(M, \zeta_m) = 1 - [1 - P_{\sqrt{M}}(M, \zeta_m)]^2 \quad (3)$$

with

$$P_{\sqrt{M}}(M, \zeta_m) = 2\left(1 - \frac{1}{\sqrt{M}}\right) \operatorname{erf}\left(\sqrt{\frac{3\zeta_m}{(M-1)}}\right) \quad (4)$$

where the  $\operatorname{erf}$  function is defined as:

$$\operatorname{erf}(x) = \int_x^\infty \frac{1}{\sqrt{2\pi}} e^{-y^2/2} dy \quad (5)$$

With Gray coding, the BER for the M-QAM can be approximated by,

$$P_b(M, \zeta_m) \approx \frac{1}{\log_2 M} P_s(M, \zeta_m) \quad (6)$$

### B. BER for RDSTC

Note that the instantaneous BER computation for the first hop of RDSTC is the same as for the direct transmission. For the second hop, we assume  $N$  nodes receive the packet correctly and participate as relays. Each relay transmits its data with a symbol energy of  $E_{s,r}$ .

We consider an underlying STC of size  $L \times K$  for RDSTC, where  $L$  is the number of antennas and  $K$  is the block length. We assume the STC is based on complex orthogonal designs [32]. For RDSTC weights represented by a vector  $\mathbf{r}_n$  for relay  $n$ , we can express the transmitted signal from the  $n^{\text{th}}$  relay at time  $k$ , as

$$z_n(k) = \sqrt{E_{s,r}} \mathbf{r}_n \mathbf{X}(k), \quad (7)$$

where  $n = 1, 2, \dots, N$  and  $k = 1, 2, \dots, K$ . Here,  $\mathbf{X}(k)$  is the  $k^{\text{th}}$  column of the STC. Note that  $\mathbf{X}(k)$  is a function of the source symbols, with the mapping determined by the underlying STC. We assume that each element of  $\mathbf{r}_n$  is an independent complex Gaussian random variable with zero mean and variance  $\frac{1}{L}$  [8].

The receiver architecture in Hop-2 is similar to a regular STC receiver with one antenna. The received signal at node  $m$  at the  $k^{\text{th}}$  symbol interval can be expressed as

$$y_m(k) = \mathbf{h}_m \mathbf{Z}(k) + w_m(k) = \sqrt{E_{s,r}} \mathbf{h}_m \mathbf{R} \mathbf{X}(k) + w_m(k) \quad (8)$$

where  $\mathbf{h}_m$  is the  $1 \times N$  channel vector,  $\mathbf{h}_m = [h_{1m} \dots h_{Nm}]$  with  $h_{im}$  representing channel gain from  $i^{\text{th}}$  relay to the  $m^{\text{th}}$  node,  $w_m(k)$  denotes additive white Gaussian noise with variance  $N_0$ .  $\mathbf{Z}(\mathbf{k})$  and  $\mathbf{R}$  can be written as,  $\mathbf{Z}(\mathbf{k}) = [z_1(k) \ z_2(k) \ \dots \ z_N(k)]^T$ ,  $\mathbf{R} = [\mathbf{r}_1 \ \mathbf{r}_2 \ \dots \ \mathbf{r}_N]^T$ .

Using pilot signals, estimation of the equivalent channel gain  $\mathbf{h}_m \mathbf{R}$  can be carried out similarly to the estimation of channel gain  $\mathbf{h}_m$  in conventional STC [8]. Assuming the  $m^{\text{th}}$  node estimates  $\mathbf{h}_m \mathbf{R}$  perfectly and using the orthogonality of the STC, the equivalent received SNR at node  $m$  is:

$$\zeta_m(\bar{\zeta}, \mathbf{h}_m, \mathbf{R}) = \frac{E_{s,r} \|\mathbf{h}_m \mathbf{R}\|^2}{N_0} = \bar{\zeta} \|\mathbf{h}_m \mathbf{R}\|^2 \quad (9)$$

We can compute the instantaneous BER of the second hop for a given set of relays by inserting (9) in (4) and then using (6).

### C. Computation of PER

Following the specifications of IEEE 802.11g standard, we employ convolutional codes of rates 1/2, 2/3 and 3/4 with generator polynomials given in [30]. We assume the bit errors in the received stream, which serves as the input to the channel decoder, are independent and identically distributed with the instantaneous BER given as in Section III-A and Section III-B, and we numerically compute the corresponding PER. For both schemes, we first generate a bit stream and encode it using a chosen convolutional code. The coded bits are flipped randomly according to the BER derived above. The output of the decoder is compared to the bitstream to determine whether a packet is received or not at a particular fading level. Note that due to fading, the received channel strength, and hence the reception of a packet at each node changes over time. For direct transmission, at each node and for a particular fading level, we first determine whether a packet is received or not using the single link BER. Then, using channel simulations, the average PER is computed over all possible fading levels. Hence, the average PER between the two nodes only depends on the modulation and the channel code as well as the distance between the nodes. For cooperative multicast, we compute the average PER from the source station to each node in two steps. We first determine whether a packet is received or not after first hop transmission based on single link BER. The nodes that receive the packets become relays. We then compute the BER of the link from relays to each node using the BER computation for RDSTC. Similar to the single link case, using channel simulations, we compute the average PER over all possible fading levels. We then find the maximum average PER,  $\epsilon_{max}$ , among all nodes, based on the average PER at each node.

## IV. PACKET LEVEL FEC AND DIRECT TRANSMISSION

In order to handle packet losses remaining after channel coding, we employ packet level FEC. The basic idea of packet level FEC is that redundant information is sent a priori by the source station, in order to be used by the receivers to correct errors/losses without contacting the source station. The advantage of using packet level FEC for multicasting is that any parity packet can be used to correct independent packet losses among different nodes. This way, we can avoid the feedback implosion problem, which occurs when the source station is overwhelmed by feedback messages from the receivers in a large multicast system. However, such a scheme introduces overhead since extra parity packets are now transmitted by the source station. Furthermore, since the FEC is applied across packets, it also introduces additional delay which will be discussed in Section VII. Despite additional overhead and delay, considering the benefits for error recovery, such a scheme is widely used in a multicast environment.

We assume that by using CRC at the link layer, each receiver is able to decide whether a packet is correctly received or not. The packets that are lost or received incorrectly can be viewed as *erasures* and an erasure code at the packet level can be used to recover the lost packets. In particular, for every  $s$  source packets, if we add  $p$  parity packets, we can recover all the

Transmission Rate, R	6Mbps	9Mbps	12Mbps	18Mbps	24Mbps	36Mbps	48Mbps	54Mbps
Modulation	BPSK	BPSK	QPSK	QPSK	QAM-16	QAM-16	QAM-64	QAM-64
Channel Code Rate	1/2	3/4	1/2	3/4	1/2	3/4	2/3	3/4

TABLE II  
TRANSMISSION RATES FOR IEEE 802.11G AND THEIR CORRESPONDING MODULATION SCHEMES AND CHANNEL CODES

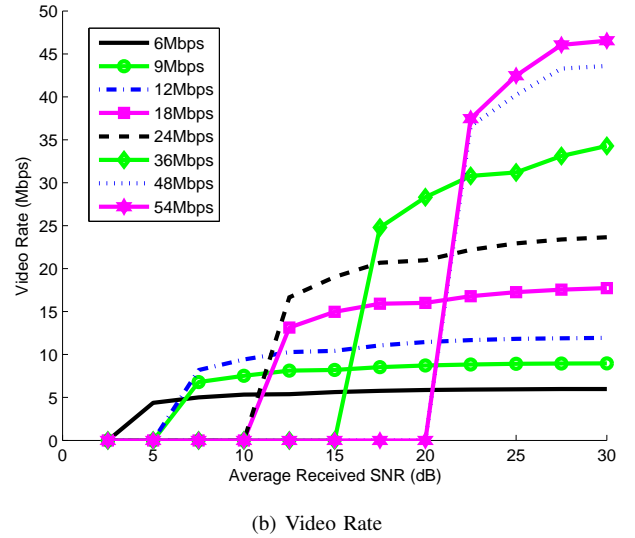
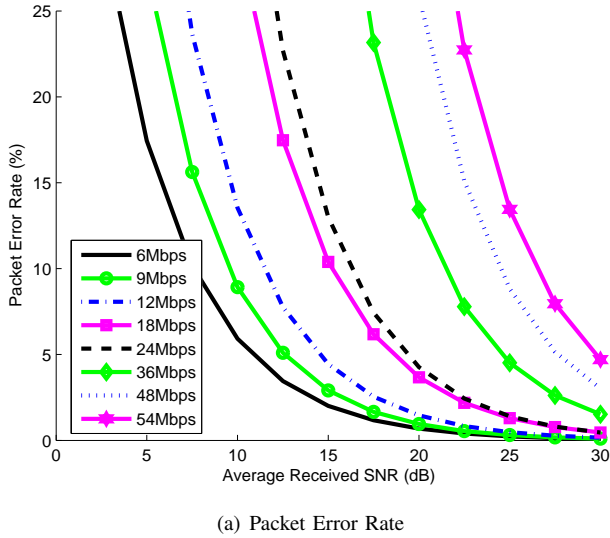

Fig. 3. PER and Video Rates vs different received SNR's for IEEE 802.11g with  $\beta = 1$ .

source packets as long as the number of erasures is at most  $p$  using *perfect* codes. Reed-Solomon (RS) code provides a good example of a perfect code [35].

The *rate* of a perfect code,  $\gamma$  is the ratio of the number of source packets to the total number of packets, that is  $\gamma = s/(s + p)$ . The FEC decoding failure probability is the probability that at least  $p + 1$  packets are in error. While evaluating the performance of the system, for given  $s$  and average PER, we numerically determine  $\gamma$  so that FEC decoding failure probability is below  $\tau = 0.5\%$ . We conducted subjective tests in our lab and observed that when using an error-resilient video decoder, typically there is no noticeable quality degradation when FEC decoding failure probability is below this threshold.

Suppose that at a direct transmission rate of  $R_d$  bits/sec, the maximum average PER among all nodes in the desired coverage radius  $r_d$  is  $\epsilon_{max}$ . Note that  $\epsilon_{max}(R_d)$  depends on the transmission rate. Hence, the packet level FEC rate  $\gamma_d(R_d)$  also depends on  $R_d$ . In a wireless network, multicast service usually uses a portion of the total available bandwidth. We define the multicast payload ratio,  $\beta$ , as the ratio of the bit rate used to transmit multicast payload data (e.g. video data including FEC parity packets) to the total transmission rate. Then, with direct transmission for a given  $\beta$ , all the nodes receive video at the same rate of:

$$R_{v_d}(R_d|\beta) = \beta\gamma_d(R_d)R_d \quad (10)$$

In conventional multicast systems (referred as *Direct*), all packets are transmitted at the base rate of the underlying network (e.g. 6Mbps for IEEE 802.11g) with a packet level FEC at fixed rate  $\gamma_d$  that is chosen based on the average

PER such that the FEC decoding failure probability is smaller than  $\tau$ . Note that, although in conventional multicast, the transmission rate and FEC rate is fixed, one can adapt the transmission rate and consequently the FEC rate based on the channel conditions to maximize the video rate in (10). We will use this observation next to improve the performance of direct transmission.

Since the transmission rate affects the FEC rate through the corresponding PER, we ran preliminary simulations using the single link packet error formulation in Section III-A, to observe the PER variation for different transmission rates and different average channel qualities between the transmitter and the receiver. In Table II, we list the physical layer transmission rates of IEEE 802.11g and their corresponding modulation and convolutional channel coding rates [30] used in our computations. In Figure 3(a), we illustrate the PER as a function of average received SNR between the transmitter and its receiver for different transmission rates as described in Section III-C. Here, we only present the results up to a PER of 25%, since for higher PER, the channel will be highly unreliable. For a fixed received SNR, we define sustainable transmission rate as the rate at which the average PER is less than 25%. Note that at a particular received SNR, among all sustainable transmission rates, the higher the transmission rate is, the higher the PER and therefore the more FEC parity packets should be transmitted. On the other hand, as the transmission rate increases, the more efficient the use of the spectrum becomes, allowing more room for extra FEC parity packets. In order to find the best transmission rate to maximize the overall video rate, we utilize the above obtained PER values along with equation (10), and depict the video rates

in Figure 3(b). Since we only consider the PER up to 25%, for each transmission rate, we can not sustain received SNR below a threshold.

We observe that as the average received SNR increases, a higher transmission rate together with lower FEC rate  $\gamma_d$  (i.e. large number of parity packets) provides higher video rates than using a lower transmission rate with higher FEC rate  $\gamma_d$ . Motivated by this observation, we also consider rate adaptation for direct transmission (*Direct-adaptive*) [18]. For *Direct-adaptive*, the transmission rates and FEC rates are dynamically adjusted according to node channel conditions to maximize the video rate in (10).

## V. PROBLEM FORMULATION FOR COOPERATIVE MULTICAST

In this section, we formulate the video rate expression for cooperative multicast. In the most general setup, we assume two-hop cooperative layered multicast where at each hop, we consider the transmission of base and enhancement layer packets. For this setup, we divide a video into segments of duration of  $T$  seconds. The time  $T$  is shared between the first and second hops. The base layer is transmitted over  $t_{1,b}$  and  $t_{2,b}$  fractions of each segment for the first and second hop respectively, where

$$t_b = t_{1,b} + t_{2,b}. \quad (11)$$

Similarly, the enhancement layer is transmitted over  $t_{1,e}$  and  $t_{2,e}$  fractions of each time interval for the first and second hop respectively, where

$$t_e = t_{1,e} + t_{2,e}. \quad (12)$$

This leads to

$$t_b + t_e = t_{1,b} + t_{1,e} + t_{2,b} + t_{2,e} = 1. \quad (13)$$

The time scheduling of the base and enhancement layers along with the transmission rates are illustrated in Figure 4.

Before formulating the video rates for randomized cooperative multicast, we discuss the practical orthogonal STC designs that are used in this paper. The orthogonal design for  $L = 2$  provides full rate for square QAM constellation [34],[32]. For higher STC dimensions, we list the best known STC rates of the orthogonal codes  $\eta$  in Table III [36]. As we increase  $L$ , on one hand we have higher diversity hence lower PER, on the other hand there is penalty in rate. Therefore while choosing the STC dimension for the cooperative multicast, one should choose  $L$  that maximizes the video rate.

Following (10), and considering the effect of the STC code rate in the second hop, the video rates for the base layer at Hop-1 and Hop-2,  $R_{v_{1,b}}$  and  $R_{v_{2,b}}$ , can be expressed as:

$$R_{v_{1,b}} = \beta\gamma_b R_{1,b} t_{1,b} \quad , \quad R_{v_{2,b}} = \beta\gamma_b \eta R_{2,b} t_{2,b} \quad (14)$$

where  $\gamma_b$  is the FEC rate for the base layer.

Similarly, the video rates for the enhancement layer at Hop-1 and Hop-2,  $R_{v_{1,e}}$  and  $R_{v_{2,e}}$ , are:

$$R_{v_{1,e}} = \beta\gamma_e R_{1,e} t_{1,e} \quad , \quad R_{v_{2,e}} = \beta\gamma_e \eta R_{2,e} t_{2,e} \quad (15)$$

where  $\gamma_e$  is the FEC rate for the enhancement layer.

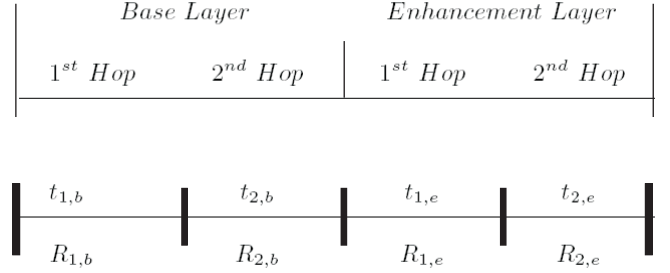

Fig. 4. Time scheduling and transmission rates for base and enhancement layers at first and second hop.

Below we study in detail the formulations for single layer and layered randomized cooperative multicast. We will discuss selection of the system operating parameters based on the available channel information in Section VI.

### A. Single layer Cooperation

For single layer cooperation, we set  $t_{1,e} = t_{2,e} = 0$  in (12), hence, we have  $t_e = 0$  and  $t_b = t_{1,b} + t_{2,b} = 1$ . The first and second hop transmission rates are  $R_1 = R_{1,b}$  and  $R_2 = R_{2,b}$ . The FEC rate  $\gamma_c = \gamma_b$  depends on the maximum average PER among all nodes after two hop transmission. Since we consider end-to-end packet level FEC, we compute the average PER experienced by each node in the multicast group using the formulation in Section III. Note that the maximum average PER, hence  $\gamma_c$ , depends on the transmission rates of both hops,  $R_1$  and  $R_2$  and the STC dimension  $L$ .

Since we would like Hop-1 and Hop-2 nodes to receive the same video rate, the transmission parameters should be chosen such that  $R_{v_{1,b}} = R_{v_{2,b}}$ . This yields  $t_{1,b} = \eta(L)R_2 / (\eta(L)R_1 + \eta(L)R_2)$ , and for a given  $\beta$ , the corresponding video rate for RDSTC can be expressed as:

$$R_{v_c}(R_1, R_2, L|\beta) = \beta\gamma_c(R_1, R_2, L) \frac{\eta(L)R_1R_2}{R_1 + \eta(L)R_2} \quad (16)$$

### B. Layered Cooperation

In order to provide nodes differentiated quality based on their channel conditions, we consider the general formulation based on two layers. For layered cooperation, we want all nodes receive the base layer at the same video rate, therefore we have  $R_{v_b} = R_{v_{1,b}} = R_{v_{2,b}}$ . This yields  $t_{1,b} = \eta(L_b)R_{2,b}t_b / (R_{1,b} + \eta(L_b)R_{2,b})$ . Then, the corresponding video rate for the base layer can be expressed as:

$$R_{v_b}(R_{1,b}, R_{2,b}, t_b, L_b|\beta) = \beta\gamma_b(R_{1,b}, R_{2,b}, L_b) \frac{\eta(L_b)R_{1,b}R_{2,b}}{R_{1,b} + \eta(L_b)R_{2,b}} t_b \quad (17)$$

where  $\gamma_b$  is the FEC rate for the base layer and is determined by the maximum PER after two hop transmission,  $\epsilon_{max}(R_{1,b}, R_{2,b}, L_b)$ .

For the enhancement layer, we consider two options: The relays either forward all the enhancement layer packets or not forward any enhancement packets at all. In both options, we require that a certain percentage of nodes  $\mu$ , receive the

STC dimension, L	2	3	4	5	6	7	8
STC code rate, $\eta$	1	3/4	3/4	2/3	2/3	5/8	5/8

TABLE III  
RATES FOR COMPLEX ORTHOGONAL DESIGNS

enhancement layer. By choosing the enhancement layer FEC rate  $\gamma_e$ , we can adjust the percentage of nodes that receive the enhancement layer with a FEC decoding failure probability below the threshold  $\tau$ . Therefore, in the first option,  $\gamma_e$  depends on the target  $\mu$  as well as  $(R_{1,e}, R_{2,e}, L_e)$ . Furthermore, since all enhancement layer packets are forwarded, we choose the transmission time such that  $R_{v_{1,e}} = R_{v_{2,e}}$ . This yields  $t_{1,e} = \eta(L_e)R_{2,e}t_e / (R_{1,e} + \eta(L_e)R_{2,e})$ . Since  $t_e + t_b = 1$ , the video rate for the enhancement layer can be expressed as:

$$R_{v_e}(R_{1,e}, R_{2,e}, t_b, L_e | \beta, \mu) = \beta \gamma_e (R_{1,e}, R_{2,e}, L_e | \mu) \frac{\eta(L_e)R_{1,e}R_{2,e}}{R_{1,e} + \eta(L_e)R_{2,e}} (1 - t_b). \quad (18)$$

Alternatively, the enhancement layer packets can go through only one hop transmission as in [14], and the source station chooses  $R_{1,e}$  and  $\gamma_e$  so that  $\mu$  percentage of nodes successfully receive the enhancement layer packets in the first hop. Since the enhancement layer packets are not forwarded, the FEC rate only depends on the first hop transmission rate,  $R_{1,e}$  as well as  $\mu$ . In this case,  $t_{2,e} = 0$ , hence,  $t_e = t_{1,e}$ . Then the video rate for the enhancement layer is:

$$R_{v_e}(R_{1,e}, t_b | \beta, \mu) = \beta \gamma_e (R_{1,e} | \mu) R_{1,e} (1 - t_b). \quad (19)$$

## VI. IMPACT OF AVAILABLE CHANNEL INFORMATION ON MULTICAST RDSTC

In this section, we discuss how to determine the system operating parameters to maximize the cooperative video rates derived in Section V, based on the available channel information. We consider three different levels of channel information. First, we assume that the source knows all the average channel qualities between itself and all the nodes, as well as among the nodes. This scheme is referred as RDSTC with full channel information, or *RDSTC* for short. In order for the source station to know the average channel qualities among the nodes, the nodes could exchange control signals among themselves to measure the average SNR, and then transmit this information back to the source station. Although having full channel information provides the best results, we recognize that the overhead may be formidable. Therefore, full channel information will be used as a benchmark for more practical schemes with partial channel information. For partial channel information, we consider two different scenarios: limited channel information and node count. For the limited channel information case, we assume the source station knows the average channel quality between itself and every node in the target coverage area. This requires channel feedback from the nodes; however in this case, inter-node channel qualities are not needed. This scheme is referred as *RDSTC-limited*. For the node count case, the only information the source station has is the number of nodes in the multicast coverage range, and this scheme is called *RDSTC-nodcount*.

In the following, we discuss the selection of system operating parameters based on these different levels of channel information.

### A. RDSTC with full channel information (RDSTC)

For *RDSTC*, for a given node placement,  $R_1, R_2, L$  and the corresponding  $\gamma_s$  are chosen through an exhaustive search. For each candidate of  $(R_1, R_2, L)$ , we determine maximum end-to-end average PER (averaged over fading) among all nodes. We determine the suitable FEC of rate  $\gamma_c$  to ensure FEC decoding failure probability is less than  $\tau$ . We search over all sustainable  $(R_1, R_2, L)$  to choose  $(R_1, R_2, L)$ , and the corresponding  $\gamma_c$  that maximize the video rate in (16).

In order to find the system operating parameters for layered cooperation of Section V-B (referred as *RDSTC-layered*), we set the video rate of the base layer to a target bit rate  $R_{v_b}^*$  and maximize the enhancement layer rate. First, we exhaustively search through  $R_{1,b}, R_{2,b}, L_b$ , and corresponding  $\gamma_b$ , to ensure the FEC decoding failure probability below  $\tau$ . Then, for a given  $R_{1,b}, R_{2,b}, L_b$ , we determine  $\gamma_b$  to maximize  $\gamma_b \frac{\eta(L_b)R_{1,b}R_{2,b}}{R_{1,b} + \eta(L_b)R_{2,b}}$  similar to single layer case. Next, we compute  $t_b$  using the selected  $R_{1,b}, R_{2,b}, \gamma_b, L_b$  such that (17) is met for the target base layer video rate  $R_{v_b}^*$ . For the enhancement layer for the two-hop case, we find all feasible  $R_{1,e}, R_{2,e}, L_e$  and the corresponding  $\gamma_e$  that guarantees the reception at  $\mu$  percent of the nodes. Then, the source station chooses  $R_{1,e}, R_{2,e}, L_e$  and the corresponding  $\gamma_e$  that maximizes,  $R_{v_e}$  in (18) by exhaustive search. For the case, when the enhancement layer is transmitted in one hop, after identifying all feasible  $R_{1,e}$  and the corresponding  $\gamma_e$ , the system operating parameters are chosen to obtain the maximum  $R_{v_e}$  in (19) for a target  $\mu$ .

For all the remaining channel information levels, we only discuss the single layer case by noting that the selection of the parameters for the layered case can be done by extending the *full-channel* information case.

### B. RDSTC with limited channel information (RDSTC-limited)

Note that with the chosen path loss model, knowing the average channel conditions (in terms of SNR) between the source station and a node is equivalent to knowing the distance between the source and the nodes, but not exactly where the node is along the circle with the radius equal to the distance. In order to compute the transmission parameters for a given set of average channel conditions between the source station and the nodes, we randomly generate multiple node placements each having all the nodes on the same set of circles which have same source-node average channel qualities. Since some node placements can be very unfavorable to cooperation, we only consider the majority of such node placements and choose the system operating parameters based on 95% of



the node placements, by not considering those 5% of node placements with the highest maximum average PER. However, when we report the system performance, we evaluate the performance for the worst 5% of the node placements as well. The system operating parameters are pre-computed only once over a large set of node placements. Note that one can choose to drop a different percentage of nodes rather than 5% to compute the system operating parameters, but there is a tradeoff between the percentage of node placements dropped and supportable video rate at remaining nodes. As the percentage of node placements dropped increases, since the remaining node placements are more favorable, the received video rate increases; however, the percentage of all nodes that receive all the packets decreases.

Specifically, for each candidate  $R_1, R_2, L$ , among all node placements with the same source-node average channel qualities, we remove the worst 5% of node placements in terms of maximum average PER, and find the maximum average PER among the remaining 95%. We set  $\gamma_c$  in (16) based on this PER. Then, among all sustainable  $(R_1, R_2, L)$ , we choose  $(R_1, R_2, L)$  and the corresponding  $\gamma_c$  that maximize the video rate in (16). In practice, a table of the system operating parameters  $(R_1, R_2, \gamma_c$  and  $L)$  for different channel conditions between the source station and the nodes, can be pre-computed and stored at the source station.

### C. RDSTC with node-count information (RDSTC-nodcount)

For a given node count, we randomly generate multiple node placements. Different from the *RDSTC-limited* scheme, here we have different source-node distances as well as different inter-node distances for a given node count. In a manner similar to Section VI-B, we do not consider worst 5% node placements with worst PER. We first find the maximum average PER among all remaining 95% node placements and compute  $\gamma_c$  based on this PER. Then we choose  $(R_1, R_2, L)$  and the corresponding  $\gamma_c$  to maximize the video rate in (16). In practice, a table of the system operating parameters  $(R_1, R_2, L$  and  $\gamma_c)$  for different numbers of nodes can be pre-computed and stored at the source station.

## VII. SIMULATION SETUP AND PERFORMANCE EVALUATION

To evaluate and compare the performances of different transmission schemes, we study an IEEE 802.11g based network. Since we modify the physical layer, we conducted the simulations in Matlab7.1 and used the modulation and channel coding rates of IEEE 802.11g as listed in Table II. In our simulations, we consider different total number of nodes,  $N_T$ , corresponding to different density networks and for each node density, we generate 200 different node placements. The nodes are randomly uniformly distributed in a coverage area with a radius of  $r_d = 100m$ , where the access point is at the center of the network. For video, we use JSVM code [9] for the H.264/SVC [33] encoder to generate video packets. We use the slice mode to limit the maximum packet size to 1400 bytes. Note that with the slice mode, a video frame with a compressed size larger than 1400 bytes will be split

into multiple slices, which are then put into separate RTP packets. Each slice is coded such that it can be decoded even if previous slices are lost. Without using the slice mode, a frame that is larger than the maximum transport unit (MTU) size in the underlying network will be fragmented into multiple RTP packets. A lost packet in a video frame may make the following packets undecodable, even if those packets are received. Therefore, using the slice mode makes the video stream more resilient to packet losses, at the cost of slightly increased bit rate for the same encoding quality. For the sequences we used in this paper, the average increase in the bit rate was less than 5%. We use Standard Definition (SD) 30Hz videos whose video rates range from 0.5Mbps to 2Mbps. The corresponding packet duration is in the order of 1ms. On the other hand the coherence time for the IEEE802.11a/g typically is 16ms for a person moving at 5km/h [31]. Therefore, we assume that the fading is constant throughout the packet. Considering that packets for the same video stream are not always sent back-to-back due to channel contention, it is reasonable to assume that consecutive packets from the same stream are separated more than the coherence interval and hence see independent fading. To compute the average PER at each node, we generate 2000 different independent fading levels for all node pairs for the same node placement. For RDSTC, we choose among STC dimensions listed in Table III.

We choose the transmission energy of the source station,  $E_{s,s}$  such that with direct transmission at the base transmission rate  $R_d = 6Mbps$ , and the nodes at the edge of the coverage range experience an average PER of 5% (before FEC), which is a typical PER assumption for wireless networks. For the same node count  $N_T$ , the selected transmission parameters and hence achievable video rates for *RDSTC*, *RDSTC-limited* and *Direct-adaptive* depend on the actual node placements, and in the performance curves presented below, we report the average video rates and the transmission rates that are averaged over all node placements.

In order to have comparable power consumption with direct transmission, we would ideally like to choose the total relay transmission energy to be equal to the source station transmission energy. However, this requires the knowledge of the number of Hop-1 nodes, which varies from packet to packet. In order to avoid the feedback needed to acquire such information, we set the relay energy per symbol for the relays in the RDSTC system to  $E_{s,r} = E_{s,s}/N_{avg}$  where  $E_{s,s}$  is the symbol energy of the source station and  $N_{avg}$  is the average number of relays. Since the symbol rate is same for all different physical transmission rates, by setting the symbol energy as above, the average power consumed by RDSTC scheme is on the average equal to direct transmission. In Figure 5, we illustrate  $N_{avg}/N_T$  versus different first hop transmission rates for different  $N_T$  (averaged over node placements and fading levels). We observe that the ratio is almost constant for different number of nodes  $N_T$ . Therefore we use this constant ratio (depending on  $R_1$ ) to normalize each relay's transmission power in all three RDSTC schemes. Note that even at the highest transmission rate, this ratio is quite large and above 0.3.

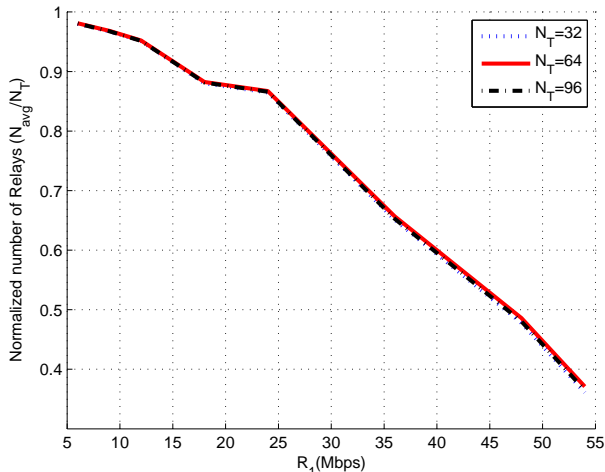

Fig. 5.  $N_{avg}/N_T$  vs  $R_1$

In our simulations, for *Direct*, since the nodes at the edge of the coverage range experience a certain average PER 5%, we apply a FEC rate of  $\gamma_d = 0.905$  such that FEC decoding failure probability is below  $\tau = 0.5\%$ . For *Direct-adaptive*, we choose  $R_d$  and corresponding  $\gamma_d$  that lead to the highest video rate in (10) by exhaustive search [18]. Note that this requires the source station to know the average channel qualities between itself and every node in the coverage area similar to *RDSTC-limited* in Section VI-B. The system operating parameters for all cooperative schemes are chosen as described in Section VI.

In Figure 6, we illustrate the achievable average video rates for different single layer schemes as a function of the number of nodes. Here we assume 10% of total available transmission rate is used for the multicast service, hence,  $\beta = 0.1$ . For *Direct*, the video rate does not change with number of nodes as transmission and FEC rates are fixed. For *Direct-adaptive*, since the transmission and FEC rates are chosen based on the node with the worst average channel condition, for a large number of nodes, there is a higher chance that there will be some node at the edge of the coverage range; hence the video rate reduces as the number of nodes increases. For cooperative multicast systems, as the number of nodes increases, more relays participate in the transmission, resulting in higher video rates. We observe that due to the STC rate  $\eta$ , even the number of nodes are high, the system chooses  $L = 2$ . The proposed schemes significantly outperform both direct transmission and rate-adaptive direct transmission as illustrated in the figure. Our results show that the performance of *RDSTC-limited* and *RDSTC-nodecount* converge as the number of nodes increases, which suggests that knowing only the node count is almost as good as knowing the average channel conditions between the source station and nodes. Note that the average video rates reported for *RDSTC-limited* and *RDSTC-nodecount* only include the best 95% node placements. We discuss the performance in the remaining 5% node placements as well as the tradeoff by choosing different percentage of best node placements below. Furthermore, the achievable video rates by both *RDSTC-limited* and *RDSTC-nodecount* are only up to 10% lower than that of the *RDSTC* requiring full channel

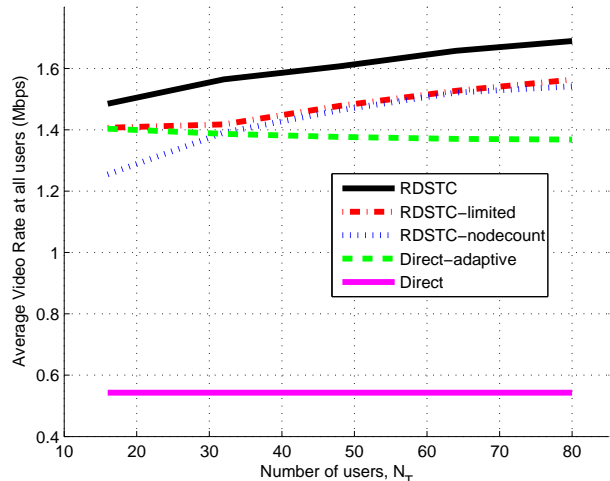

Fig. 6. Average video rates vs number of nodes for single layer systems ( $\beta = 0.1$ ).

information. This demonstrates that cooperation using *RDSTC* is indeed very robust and capable of near optimal performance even without full channel information.

In Figure 7, for different node counts, we present the average operating transmission rates ( $R_1, R_2$ ) and the corresponding FEC rates  $\gamma$ . We observe that as the number of nodes increases, the average first hop transmission rate for *RDSTC* is close to 54Mbps and the corresponding  $N_{avg}/N_T$  ratio is around 0.4 (see Figure 5). This means for each packet, almost half of the nodes receive the packet correctly and participate in the second hop transmission. Furthermore, we show that, even when the system operating parameters are chosen with partial channel information, they are close to those of *RDSTC* with full-channel information.

Recall that in *RDSTC-limited* and *RDSTC-nodecount*, the system operating parameters are chosen based on the best 95% of the node placements. All nodes in these placements receive video packets with a FEC decoding failure probability of less than  $\tau = 0.5\%$ . Note that in the 5% worst node placements, many nodes actually have PER less than the maximum PER in the 95% node placements considered. Hence these nodes can also receive all the packets with a decoding failure rate less than  $\tau = 0.5\%$ . In Figure 8, we consider all the node placements (including the worst 5% of node placements) and present the percentage of nodes that receive all the packets with a FEC decoding failure probability of less than  $\tau = 0.5\%$ . We observe that even though the system operating parameters were chosen without considering 5% worst node placements, for a high density network, almost all the nodes receive all the packets. We further evaluate the video rate performance for different percentage of worst node placements in Table IV. Note that as we increase the percentage of the worst node placements, since we are only guaranteeing delivery to fewer number of node placements, the average video rate increases.

For layered cooperation, we only evaluate the performance of layered *RDSTC* under full channel information (*RDSTC-layered*), but the results can be extended to other schemes easily. In Figure 9(a), we illustrate the average video rates, for

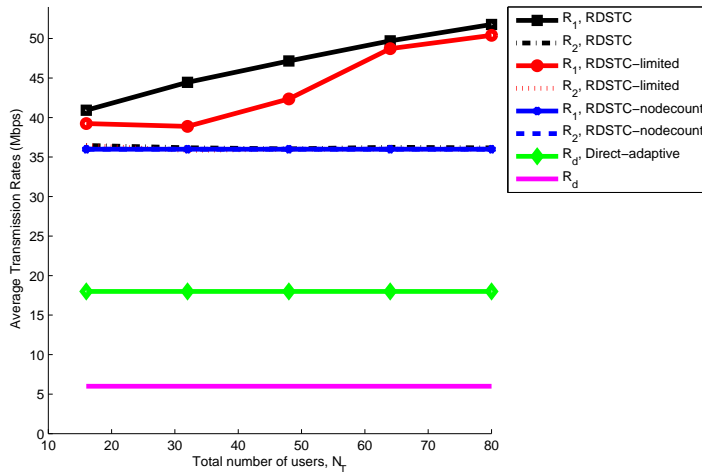

(a) Average transmission rates

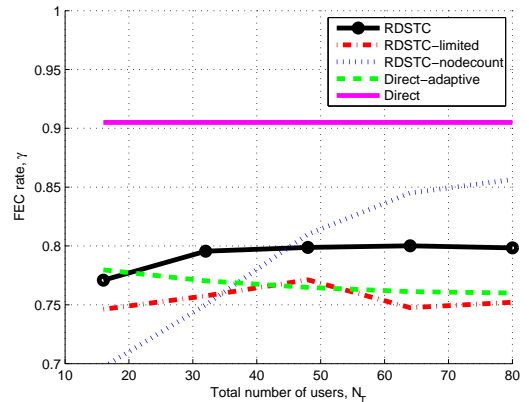

(b) Average FEC rates

Fig. 7. Transmission rates and FEC rates for single layer systems

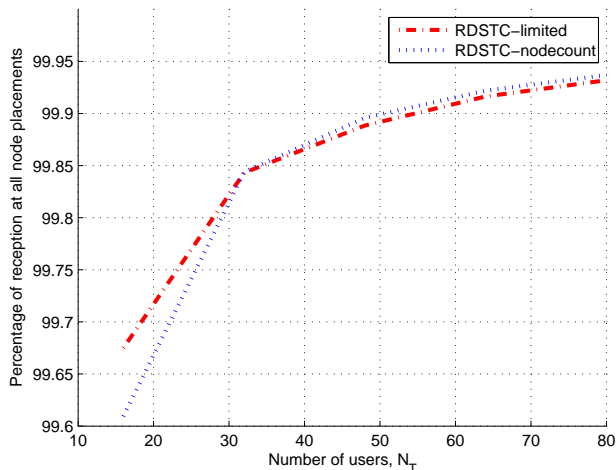
Fig. 8. Percentage of nodes to receive all packets at all node placements versus number of nodes,  $N_T$ 

	1%	5%	20%
$N_T = 48$	1.432 Mbps	1.464 Mbps	1.523 Mbps
$N_T = 80$	1.509 Mbps	1.542 Mbps	1.558 Mbps

TABLE IV

THE EFFECT OF DIFFERENT PERCENTAGE OF WORST NODE PLACEMENTS ON AVERAGE VIDEO RATES FOR *RDSTC-nodccount* ( $\beta = 0.1$ )

*RDSTC-layered* and *Direct-adaptive-layered* with  $\mu = 30\%$ , and compare with *RDSTC* as well as direct transmission schemes. Here we set the base layer rate to  $R_{v_b}^* = 1.5R_{v,d}$  where  $R_{v,d}$  is the video rate for direct transmission and evaluate the video rate of the enhancement layer,  $R_{v_e}$ . With layered randomized cooperation,  $\mu = 30$  percent of the nodes observe significant improvement on the video rate compared to single layered randomized cooperation while the remaining nodes still experience a much better video quality than direct transmission. Furthermore, layered randomized cooperation

outperforms layered direct transmission. In Figure 9(b), for a fixed number of nodes, we present the achievable total video rates ( $R_{v_b} + R_{v_e}$ ) as a function of  $\mu$  for the same base layer rate above. Recall that  $\mu$  is the percentage of nodes receiving both layers, while  $100 - \mu$  is the percentage of nodes receiving only base layer, hence as we increase  $\mu$ , the total achievable video rate reduces, as we provide this rate to more nodes.

Note that under the same video rate, the perceptual video quality depends on the characteristics of the underlying video with a video containing fast moving objects and fine texture having a lower quality. In order to evaluate the gain in video quality brought by the increase in the video rate, we report the video quality achievable at the supported video rates by different schemes for two different SD resolution (704x576) videos: Harbor and Terrace. The Harbor sequence features many parked or moving ships in a crowded harbor and the movements are mainly attributed to the moving ships in the harbor, as well as the ripples in the water. The Terrace sequence shows the internal terrace of a well-lit building, occasionally with people passing by. The scene content is relatively simple. From our own perceptual observation, we have found that as long as the FEC decoding failure probability is below the chosen threshold  $\tau = 0.5\%$ , the loss effect is hardly noticeable, the decoded video quality is almost equal to the encoded video quality and depends only on the video rate. Here, we use the Peak Signal to Noise Ratio (PSNR) to evaluate the video quality, which is commonly used by the video coding community, and correlates reasonably well with perceptual quality when the video is free from packet loss artifacts and the bit rate is not very low. Considering the range of SD video rates, we use  $\beta = 0.1$ . In Table V, we report the PSNR corresponding to the average video rates supported by different transmission schemes for a dense network ( $N_T=80$ ). For Terrace sequence, single layer cooperative multicast achieves 7.09dB and 1.05dB improvement compared to direct transmission and rate adaptive direct transmission, respectively. Layered cooperation provides further PSNR gains

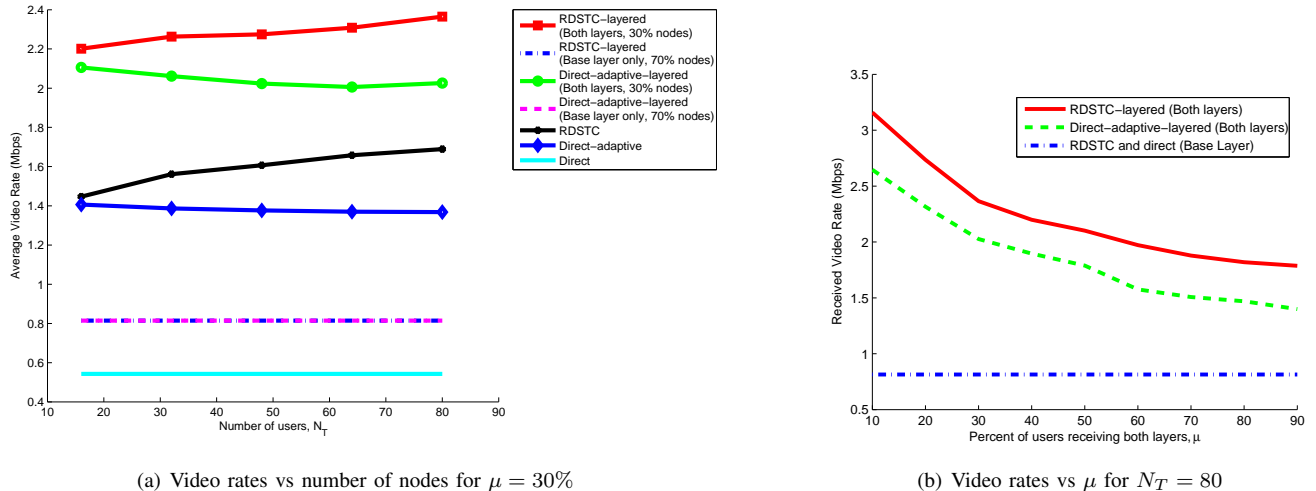

Fig. 9. Average video rates for layered cooperation for different  $N_T$  and  $\mu$  ( $\beta = 0.1$ ).

	<i>Direct</i>	<i>Direct-adaptive</i>	<i>RDSTC</i>	<i>RDSTC-layered (Both Layers)</i>	<i>RDSTC-layered (Base Layer)</i>
<b>Supportable Video Rates</b>	0.54 Mbps	1.37 Mbps	1.69 Mbps	2.37 Mbps	0.81 Mbps
<b>Harbor</b>	26.54 dB	30.30 dB	31.17 dB	32.55 dB	28.19 dB
<b>Terrace</b>	29.17 dB	35.75 dB	36.80 dB	37.87 dB	33.13 dB

TABLE V  
VIDEO QUALITY IN AVERAGE PSNR (DB) FOR DIFFERENT TRANSMISSION SCHEMES ( $\beta = 0.1$ ,  $N_T = 80$ ,  $\mu = 30\%$ )

of up to 8.70dB for nodes with good channel quality (that receive both layers) whereas the nodes with bad channel conditions (that receive only the base layer) experience a PSNR improvement of 3.96dB compared to direct transmission. Such gains in PSNR lead to significant visual improvement. For the Harbor sequence, relatively lower gains are achievable, but are still significant.

Finally, we discuss the delay introduced by FEC into the direct transmission and cooperative multicast system. In a system that adds  $p$  parity packets to each block of  $s$  source packets, the receiver must wait for  $n = s + p$  packets before FEC decoding. Therefore the maximum delay due to FEC decoding is the time needed to transmit  $n$  packets. Since the received video rate already considers the parity packets and  $\beta$ , the delay is  $D = L_p s / R_v$ , where  $L_p$  is the packet size and  $R_v$  is the received video rate. In our case, we use  $s = 128$  packets and  $L_p = 1400$  Bytes. Recall that the supportable video rate depends on  $N_t$  and  $\beta$ . For  $N_t = 80$  and  $\beta = 0.1$ , the average supportable video rates by *Direct*, *Direct-adaptive* and *RDSTC* are 0.54Mbps, 1.37Mbps and 1.69Mbps, respectively (see Table V). This leads to delays of 2.640, 1.040 and 0.849 seconds, respectively. Since cooperative multicast can support higher video rates, it also leads to a smaller delay compared to the direct transmission. Note that this delay only causes initial play-out delay, which is acceptable for multicast applications. For live streaming applications, FEC encoding has to be done on the fly. Note that for on the fly FEC encoding, the sender can still transmit the source packets while buffering them for the FEC encoding. When there are enough packets in the buffer, the sender generates and transmits the

FEC packets introducing FEC encoding delay to the system which is negligible. The previous discussion is for single layer cooperative multicast and similar computations can be carried out for the layered case as well.

## VIII. CONCLUSION

In this paper, we propose a cooperative layered video multicasting scheme using RDSTC along with packet level FEC to enable error resilient video delivery. We choose the transmission rates of the first and second hops, STC dimension and FEC rate to maximize the achievable video rate at all nodes in the single layer system. In the layered case, we maximize the video rate of the enhancement layer given a target base layer video rate and a percentage of nodes  $\mu$  that receive both base and enhancement layers. We further discuss the impact of the available channel information, and propose three different schemes to choose the system operating parameters based on the available network state information for the RDSTC scheme. Our results show that rate adaptive direct transmission provides more than two times higher video rates as compared to conventional multicast. For single layer cooperative with full channel information, the supportable video rate is more than three times higher than conventional multicast. For the layered case with full channel information, closer nodes experience up to five times higher video rates, depending on  $\mu$ , while the distant nodes still experience much higher video rates compared with the direct transmission. We observe that RDSTC with limited channel information and RDSTC with node count perform similarly when there are a large number of nodes in the network. We show that even when

the transmission parameters are chosen with partial channel information (for example, only based on node count), the robustness of RDSTC ensures that the performance loss is negligible compared to RDSTC with full channel information.

In the proposed scheme in this paper, the relays forward all the packets without differentiating between the source and parity packets. Furthermore, the parity packets are only generated at the source station. A future research direction considers enabling FEC encoding at the relays to forego first hop transmission of parity packets in order to improve the overall multicast performance. With such a design, parity packets are generated by the nodes that receive the source packets correctly, and these parity packets are only transmitted in the second hop using RDSTC. Preliminary investigation of this approach has shown promising improvement over the RDSTC scheme presented here [37].

## REFERENCES

- [1] A. Sendonaris, E. Erkip, and B. Aazhang, "User cooperation diversity-Part I: System Description," *IEEE Transactions on Communications*, vol. 51, pp. 1927-38, November 2003.
- [2] A. Sendonaris, E. Erkip, and B. Aazhang, "User cooperation diversity-Part II: Implementation aspects and performance analysis," *IEEE Transactions on Communications*, vol. 51, pp. 1939-48, November 2003.
- [3] J. N. Laneman, D. N. C. Tse, and G. W. Wornell, "Cooperative diversity in wireless networks: Efficient protocols and outage behavior," *IEEE Transactions on Information Theory*, vol. 50, no. 12, pp. 3062, December 2004.
- [4] H. Y. Shutoy, D. Gunduz, E. Erkip and Y. Wang, "Cooperative source and channel coding for wireless multimedia communications," *IEEE Journal of Selected Topics In Signal Processing*, Vol. 1, Issue 2, pp. 295, Aug. 2007
- [5] D. Gunduz and E. Erkip, "Source and channel coding for cooperative relaying," *IEEE Transactions on Information Theory, Special Issue on Models, Theory, and Codes for Relaying and Cooperation in Communication Networks*, vol. 53, no. 10, pp.3453 – 3475, October 2007
- [6] V. Tarokh, H. Jafarkhani, and A. Calderbank, "Space-time block codes from orthogonal designs," *IEEE Transactions on Information Theory*, vol. 45, no. 5, pp. 1456-1467, July 1999.
- [7] S. Alamouti, "A simple transmit diversity technique for wireless communications," *IEEE Journal on Selected Areas in Communications*, vol. 16, no. 8, pp. 1451-1458, October 1998.
- [8] B. S. Mergen and A. Scaglione, "Randomized space-time coding for distributed cooperative communication," *IEEE Transactions on Signal Processing*, pp. 5003-5017, October 2007.
- [9] Joint Scalable Video Model (JSVM), "JSVM Software, Joint Video Team, Doc. JVT-X203, Geneva, Switzerland, June 2007.
- [10] M. Sharp, A. Scaglione and B. Sirkeci-Mergen, "Randomized Cooperation in Asynchronous Dispersive Links," *IEEE Transactions on Communications*, vol. 57, no. 1, pp. 64-68, January 2009.
- [11] F. Verde, T. Korakis, E. Erkip, and A. Scaglione, "On avoiding collisions and promoting cooperation: Catching two birds with one stone," in *Proceedings of IEEE SPAWC*, July 2008.
- [12] P. Liu, Y. Liu, T. Korakis, A. Scaglione, E. Erkip, S. Panwar, "Cooperative MAC for rate adaptive randomized distributed space-time coding, in *Proceedings of IEEE GLOBECOM*, November 2008.
- [13] P. Liu, C. Nie, E. Erkip and S. Panwar, "Robust cooperative relaying in a wireless LAN: Cross-layer design and performance analysis, in *Proceedings of IEEE GLOBECOM*, December 2009.
- [14] O. Alay, P. Liu, Z. Guo, L. Wang, Y. Wang, E. Erkip, S. Panwar, "Cooperative layered video multicast using randomized distributed space-time codes", in *Proceedings of IEEE Infocom MOVID Workshop*, Rio De Janeiro, Brazil, April, 2009.
- [15] O. Alay, P. Liu, Y. Wang, E. Erkip, S. Panwar, "Error resilient video multicast using randomized distributed space-time codes", in *Proceedings of IEEE ICASSP*, Dallas, TX, March, 2010.
- [16] S.-H.G. Chan, X. Zheng, Q. Zhang; W.-W. Zhu, Y.-Q. Zhang, "Video loss recovery with FEC and stream replication," *IEEE Transactions on Multimedia*, Volume: 8 , Issue: 2 , 2006 , Page(s): 370 - 381
- [17] I. V. Bajic, "Efficient cross-layer error control for wireless video multicast," *IEEE Transactions on Broadcasting*, Volume: 53, Issue: 1, 2007, Page(s): 276 - 285
- [18] O. Alay, T. Korakis, Y. Wang, S. Panwar, "Dynamic rate and FEC adaptation for video multicast in multi-rate wireless networks", *ACM/Springer Mobile Networks and Applications (MONET), Special Issue on Advances In Wireless Testbeds and Research Infrastructures*, Volume 15, Issue 3, 2010, pp 425.
- [19] H. Yousefi'zadeh, H. Jafarkhani, A. Habibi, "Layered media multicast control (LMMC): real-time error control," *IEEE Transactions on Multimedia*, Volume: 8, Issue: 6, 2006, Page(s): 1219 - 1227
- [20] A. Majumdar, D. Sachs, I. Kozintsev, K. Ramchandran, and M. M. Yeung, "Multicast and Unicast Real-Time Video Streaming over Wireless LANs," *IEEE Transactions on Circuits and Systems for Video Technology*, vol. 12, June 2002. pp.524-534.
- [21] T. A. Lee, S. G. Chan, Q. Zhang, W. Zhu, and Y. Zhang, "Allocation of layer bandwidths and FECs for video multicast over wired and wireless networks," *IEEE Transactions on Circuits and Systems for Video Technology*, vol. 12, no. 12, December 2002. pp 1059-1070.
- [22] T. Kim and M. Ammar. "A comparison of heterogeneous video multicast schemes layered encoding or stream replication," *IEEE Transactions on Multimedia*, 7(6):11231130, December 2005.
- [23] C. Cordeiro, H. Gossain and D. Agrawal, "Multicast over Wireless Mobile Ad Hoc Networks: Present and Future Directions," *IEEE Network, SI on Multicasting: An Enabling Technology*, January/February 2003.
- [24] S.J. Lee, W. Su, J. Hsu, M. Gerla, R. Bagrodia, "A Performance Comparison Study of Ad Hoc Wireless Multicast Protocols," in *IEEE INFOCOM*, 2000.
- [25] S. Mao, X. Cheng, Y. T. Hou, and H. Sherali, "Multiple Tree Video Multicast Over Wireless Ad-Hoc Networks," in *IEEE BROADNETS*, 2004.
- [26] W. Wei and A. Zakhori, "Multiple Tree Video Multicast Over Wireless Ad-Hoc Networks," *IEEE Transactions on Circuits and Systems for Video Technology*, 17(1):215, January 2007.
- [27] C. Chou, A. Misra, and J. Qadir, "Low Latency Broadcast in Multi-Rate Wireless Mesh Networks," *IEEE JSAC SI on Multi-hop Wireless Mesh Networks*, 2006.
- [28] X. Zhu, T. Schierl, T. Wiegand, B. Girod, "Video multicast over wireless mesh networks with scalable video coding (SVC)," in *VCIP*, 2008.
- [29] O. Alay, T. Korakis, Y. Wang, E. Erkip, S. Panwar, "Layered Wireless Video Multicast Using Relays," *IEEE Transactions on Circuits and Systems for Video Technology*, (in press)
- [30] LAN MAN Standards Committee of the IEEE Computer Society, ANSI/IEEE Std 802.11, "Part 11: Wireless LAN medium access control (MAC) and physical layer (PHY) specifications: high-speed physical layer extension in the 2.4 GHz Band," IEEE 802.11 Standard, 1999.
- [31] W. Vereecken, M. Steyaert, "Ultra-Wideband Pulse-based Radio: Reliable Communication over a Wideband Channel", Springer, 2009, pp. 37
- [32] H. Jafarkhani, "Space-time coding: theory and practice", Cambridge University Press, 2005
- [33] H. Schwarz, D. Marpe and T. Wiegand., "Overview of the Scalable Video Coding Extension of the H.264/AVC Standard," *IEEE Transactions on Circuits and Systems for Video Technology*, Vol:17, Issue 9 pp. 1103 - 1120 September 2007.
- [34] J. G. Proakis, "Digital communications", New York, McGraw-Hill, 2001.
- [35] I. S. Reed and G. Solomon, "Polynomial codes over certain finite fields", *J.Soc. Industrial Appl. Math.*, vol. 8, pp. 300-3004, 1960
- [36] K. Lu, S. Fu, X.-G. Xia, "Closed-form designs of complex orthogonal space-time block codes of rates (k+1)/(2k) for 2k-1 or 2k transmit antennas," *IEEE Transactions on Information Theory*, vol. 51, issue. 12, pp. 4340-4347, December 2005.
- [37] O. Alay, Z. Guo, Y. Wang, E. Erkip, S. Panwar, "Enhanced Parity Packet Transmission for Video Multicast using R-DSTC", in *Proceedings of IEEE PIMRC*, Istanbul, Turkey, September 2010.



**Ozgu Alay** (S'05) received the B.S. and M.S. degrees in Electrical and Electronics Engineering from Middle East Technical University, Ankara, Turkey, in 2003 and 2006 respectively. She is currently working toward her Ph.D. at Polytechnic Institute of New York University. Her research interests lie in the areas of multimedia signal processing and communication with special emphasis on video compression and wireless multimedia transmission.



**Elza Erkip** (S'93-M'96-SM'05-F'11) received the B.S. degree in electrical and electronics engineering from the Middle East Technical University, Ankara, Turkey, and the M.S. and Ph.D. degrees in electrical engineering from Stanford University, Stanford, CA. Currently, she is a Professor of electrical and computer engineering at the Polytechnic Institute of New York University, Brooklyn. In the past, she has held positions at Rice University, Houston, TX, and at Princeton University, Princeton, NJ. Her research interests are in information theory, communication

theory, and wireless communications.

Dr. Erkip received the National Science Foundation CAREER Award in 2001, the IEEE Communications Society Rice Paper Prize in 2004, and the ICC Communication Theory Symposium Best Paper Award in 2007. She co-authored a paper that received the ISIT Student Paper Award in 2007. She was a Finalist for The New York Academy of Sciences Blavatnik Awards for Young Scientists in 2010. Currently, she is an Associate Editor for the IEEE TRANSACTIONS ON INFORMATION THEORY. She was an Associate Editor for the IEEE TRANSACTIONS ON COMMUNICATIONS from 2006-2009, a Publications Editor for the IEEE TRANSACTIONS ON INFORMATION THEORY from 2006-2009, and a Guest Editor of the IEEE Signal Processing Magazine in 2007. She was the technical program co-chair of WiOpt 2011, the co-chair of the GLOBECOM Communication Theory Symposium in 2009, the publications chair of ITW Taormina in 2009, the MIMO Communications and Signal Processing Technical Area chair of the Asilomar Conference on Signals, Systems, and Computers in 2007, and the technical program co-chair of the Communication Theory Workshop in 2006.



**Pei Liu** (S'97-M'09) received his B.S. and M.S. degrees in electrical engineering from Xian Jiaotong University, China, in 1997 and 2000, respectively and the Ph.D. degree in Electrical and Computer Engineering from Polytechnic University in 2009. He is currently a Research Assistant Professor in the Electrical and Computer Engineering Department of Polytechnic Institute of NYU. He is also affiliated with the New York State Center for Advanced Technologies in Telecommunications (CATT) and the Wireless Internet Center for Advanced Technology

(WICAT) at Polytechnic Institute of NYU. His research interests are in mobile and wireless systems.



**Shivendra S. Panwar** (S'82-M'85-SM'00-F'11) is a Professor in the Electrical and Computer Engineering Department at Polytechnic Institute of New York University. He received the B.Tech. degree in electrical engineering from the Indian Institute of Technology, Kanpur, in 1981, and the M.S. and Ph.D. degrees in electrical and computer engineering from the University of Massachusetts, Amherst, in 1983 and 1986, respectively. He joined the Department of Electrical Engineering at the Polytechnic Institute of New York University, Brooklyn in 1985.

He is currently the Director of both the New York State Center for Advanced Technology in Telecommunications (CATT) and the Wireless Internet Center for Advanced Technology (WICAT), an NSF Industry-University Cooperative Research Center. His research interests include the performance analysis and design of networks. Current work includes cooperative wireless networks, switch performance and multimedia transport over networks. He has served as the Secretary of the Technical Affairs Council of the IEEE Communications Society. He is a co-winner of the IEEE Communications Society Leonard G. Abraham Prize Paper Award in the Field of Communications Systems in 2004. He has co-authored TCP/IP Essentials: A Lab based Approach, published by the Cambridge University Press.



**Yao Wang** (M'90-SM'98-F'04) received the B.S. and M.S. degrees in Electronic Engineering from Tsinghua University, Beijing, China, in 1983 and 1985, respectively, and the Ph.D. degree in Electrical and Computer Engineering from University of California at Santa Barbara in 1990. Since 1990, she has been with the Electrical and Computer Engineering faculty of Polytechnic Institute of New York University. Her research interests include video coding and networked video applications, medical imaging and pattern recognition. She is a co-winner of the

IEEE Communications Society Leonard G. Abraham Prize Paper Award in the Field of Communications Systems in 2004. She is the leading author of the textbook Video Processing and Communications. She was elected Fellow of the IEEE in 2004 for contributions to video processing and communications.